

Communications & Power Industries Klystron Transmitter



The CPI BMD 3 MW, S Band, Klystron transmitter is available for surveillance radar. This microwave transmitter uses a CPI Klystron amplifier (VKS 8345) as the RF output device. CPI is able to furnish a compact, user-friendly, cost-effective microwave power source with excellent pulsed Doppler capability. The transmitter controller offers ethernet connectivity for the user and OEM.

The transmitter that CPI provides includes the high voltage power supply, solenoid power supply, solenoid for the Klystron, 3000 kW S-band Klystron, solid state switch and the high voltage oil tank assembly which includes the pulse transformer, energy storage high voltage capacitor, filament power supply. The overall assembly size is 60 inches wide by 32 inches deep by 60 inches tall.

The CPI BMD high voltage power supply provides 35 kW of DC energy to the solid state switch assembly. The high voltage power supply is a 19 inch rack mount unit, 21.5 inches high by 26.5 inches deep. It is completely self-protected with over-current and input under/over voltage circuits. The high voltage power supply converts the prime power input AC into DC then switches it utilizing a short-circuit proof series resonant inverter. Auxiliary power supplies needed to operate the Klystron are contained in the interface assembly, including a filament power source, ion pump source, and low voltage bias supplies. The external interface and control is done in this supply. Cooling is accomplished by liquid cooling and internal fans.

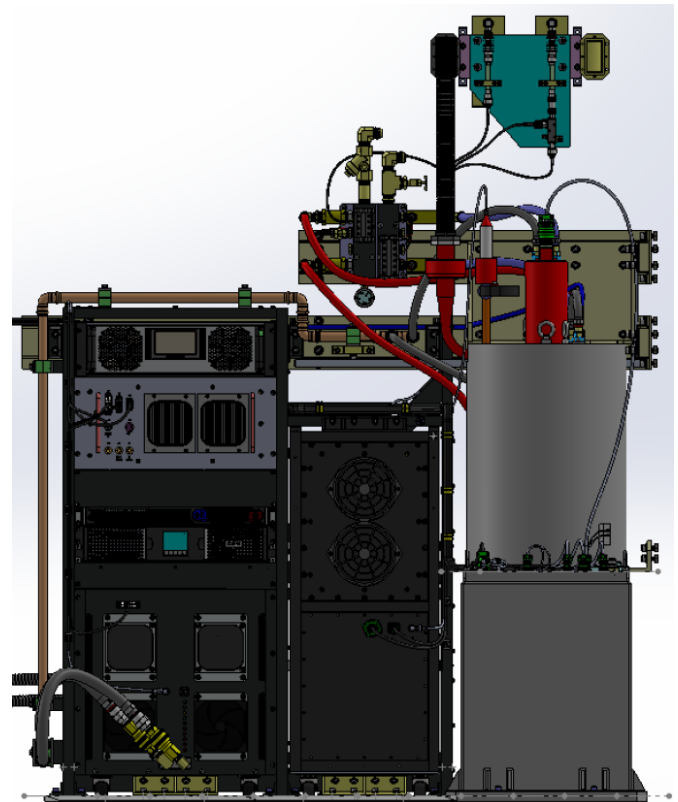

FEATURES:

- 3 MW peak power RF output
- Modular design for ease of customization
- Air and liquid cooled

BENEFITS:

- CPI BMD Klystrons and modulators ensure compatible performance
- Easy to use and user friendly
- Built in diagnostics and BIT for local or remote troubleshooting.

APPLICATIONS:

- Surveillance radars
- Instrumentation radars

CPI Klystron Transmitter

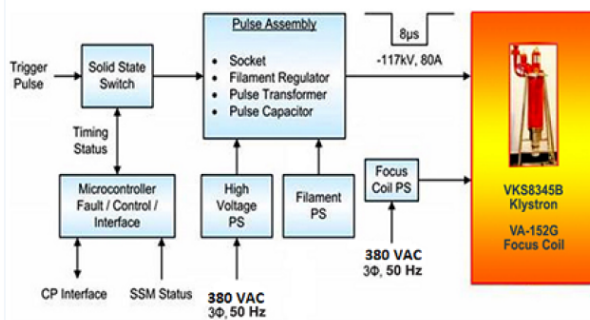

All high voltage is contained in an oil tank. The Pulse Transformer that steps up the HVPS output to the high voltage that the Klystron requires, the storage capacitor to supply the energy during the pulse for good RF pulse fidelity, and the Klystron filament DC filter are all contained in this oil tank. The Solenoid and the Klystron are mounted on the top of the oil tank with the bushing of the Klystron going into the oil tank and immersed in the oil. External fans are required to cool the klystron and the solenoid. The liquid cooling is interlocked as the Klystron and Solenoid can be damaged if sufficient cooling is not supplied.

The Solid-State Switch Assembly is located close to the High Voltage Oil Tank Assembly so that there is minimal inductance in the buss-line that is carrying the current to the Step-up Transformer. Beam switching is done by a solid-state array of IGBT switch boards that is driven by the control interface board in the HVPS. The IGBT switch is a current controlled switch, set by a bias voltage from the HVPS control interface board. The voltage across the switch will change automatically as the voltage across the klystron changes due to frequency and temperature changes. These switches have graceful degradation, allowing the unit to continue to operate in the event of a fault in a switch board. The modulator switch assembly has integral fans to cool the switches.

The COTS solenoid power supply is a separate 19 inch rack power supply that is (3U) 5.25 inches high by 21.5 inches deep. The solenoid power supply is current controlled because the voltage to the coil will change as the temperature of the solenoid coil changes.

Instrumentation and control

The transmitter controller offers Ethernet connectivity for the user and OEM. (RS422 is available as an option) BITE, status information and operating parameters are also available to the radar operator for remote monitoring of the equipment. At the front panel of the transmitter five (5) test points are available. These are RF input sample, RF output forward power sample, RF output reflected power sample, RF gate pulse sample and the modulator gate pulse sample.

In addition to prime power and control signals via the Ethernet line to the transmitter the radar system controller must provide a +10V gate signal to the CPI transmitter that determines the duration the IGBT switch is on (which determines the duration of the klystron beam pulse and the PRF). If the exciter is CW then the system controller also needs to provide an RF gate signal to the transmitter for nesting the RF pulse within the klystron beam pulse.

Cabinetry

The transmitter outline is approximately 60 inches wide by 32 inches deep by 60 inches tall. The waveguide is designed to exit at the top of the area. Weight is approx. 2000 lbs.

The transmitter subassemblies are designed to fit into standard width cabinets. The HV tank and IGBT switch are located next to each other due to the necessity of minimizing inductance between the two assemblies. The HVPS and Solenoid power supply and driver are located in the cabinet enclosure. Due to the klystron weight a special hoist is available to enable easy removal of the klystron for maintenance and troubleshooting.

The transmitter area will need to exchange cooling air to remove 5 kW of power and keep the internal temperature under 50° C. The modulator enclosure cooling air is filtered so debris will not get to high voltage areas. These filters need to be changed periodically based on the amount of debris in the area.

CPI Klystron Transmitter

Fault Protection

Monitor and shut off triggers for:

- Peak and average beam current
- Filament power supply regulation and current
- Excessive duty cycle from gate signal
- Solenoid current fault
- Ion power supply current
- High voltage under voltage and over current
- Low voltage power supply under voltage
- High voltage power supply and modulator
- Tank oil level window
- Low Liquid flow

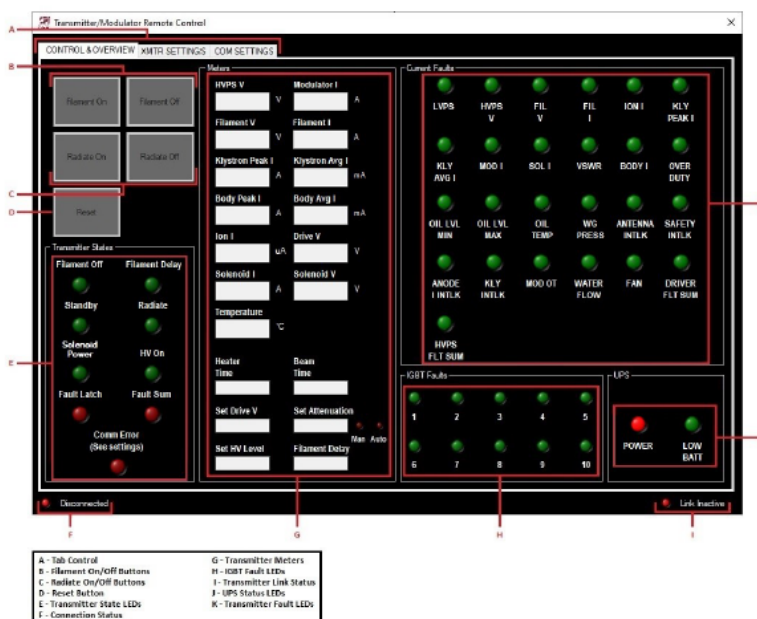

SPECIFICATION	DESCRIPTION	COMMENTS
Modulator Type	Solid state, cathode pulsed	IGBT switch modulator, current controlled
Dimensions	60"W x 32"D x 50"H	Equipment and modulator rack mount
Input voltage	400vac 3phase, 50/60hz, +/-5%	0.85 power factor minimum
RF Output power	3 MW peak	This is adjustable via beam drive on gui
Frequency	2.9 - 3.1 GHz	Fixed bandwidth
Gain	95dB	Nominal
Coherency	55dB	Dependent on coherency of RF drive, equal to an RMS phase error of approximately 0.1°rms
Pulse widths	In response to input gate - Adjustable from 1.0 to 7.0us	The PW is continuously variable based on input gate
PRF	Minimum: 250 Hz Maximum: 300 Hz	
Duty cycle	0.002	RF duty, (Beam duty 0.003)



Beverly Microwave Division
 150 Sohier Road
 Beverly, Massachusetts
 USA 01915

tel +1 978-922-6000
 email BMDMarketing@cpii.com
 fax +1 978-922-8914
 web www.cpii.com

For more detailed information, please refer to the corresponding CPI technical description if one has been published, or contact CPI. Specifications may change without notice as a result of additional data or product refinement. Please contact CPI before using this information for system design.

©2020 Communications & Power Industries LLC. Company proprietary: use and reproduction is strictly prohibited without written authorization from CPI.