

FLAT PARABOLIC SURFACE FLAPS™ Antenna Technology

Abstract

A FLAPS™ reflector is a thin (planar or conformal) surface consisting of an array of elements, each functioning as a radiator and phase shifter. Unlike a conventional planar array, however, the elements on the FLAPS™ surface are spatially fed using a feed assembly as in a conventional reflector system. This results in an antenna technology that offers the advantages of both planar arrays and reflector systems. Additionally, FLAPS™ technology offers packaging and deployment ease, and is suitable to a variety of manufacturing processes and procedures using low-cost materials. Other features such as polarization control, large apertures with low windloading, and low-cost electronic beam switching and scanning are also possible. Initially developed for defense microwave and millimeter-wave radar applications, FLAPS™ antennas are now being developed and fielded in many defense as well as commercial radar and communications systems.

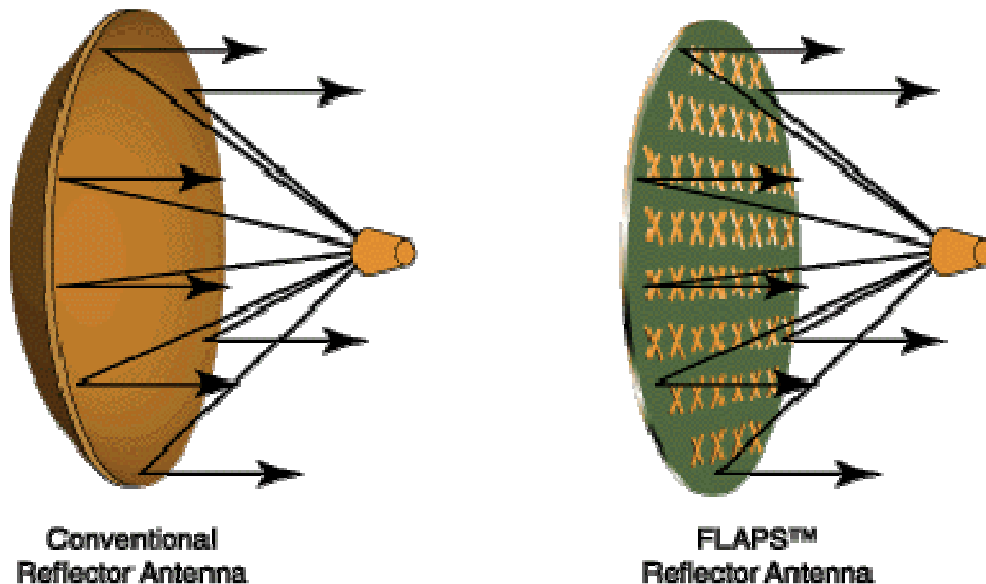

INTRODUCTION

"Flat Parabolic Surface" (FLAPS™) at first may seem like an oxymoron but in fact, it is possible to design a geometrically flat surface to behave electromagnetically as though it were a parabolic reflector.

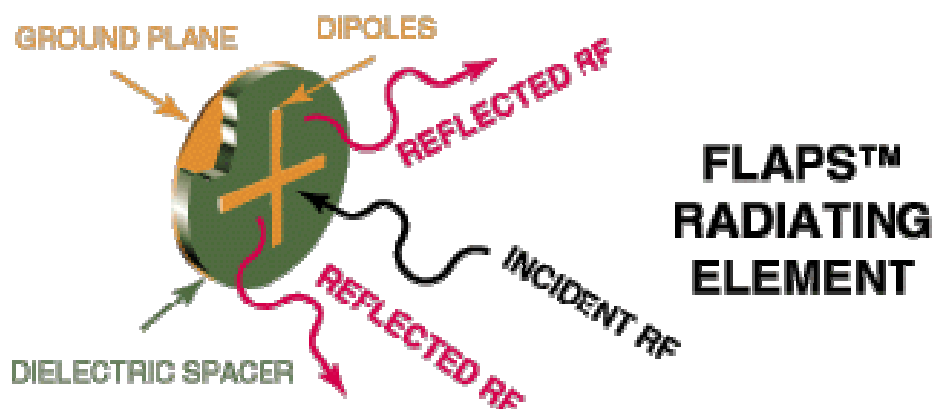

The FLAPS™ consists of an array of dipole scatterers. The elemental dipole scatterer consists of a dipole positioned approximately $1/8$ wavelength above a ground plane. Here, a crossed shorted dipole configuration is shown with each dipole controlling its corresponding polarization. Incident RF energy causes a standing wave to be set up between the dipole and the ground-plane. The dipole itself possesses an RF reactance that is a function of its length and thickness. This combination of standing wave and dipole reactance causes the incident RF to be reradiated with a phase shift ϕ , which can be controlled by a variation of the dipole's length. The exact value of this phase shift is a function of the dipole length, thickness, its distance from the ground-plane, the dielectric constant of the intervening layer, and the angle of the incident RF energy. When the element is used in an array, as discussed later, it is also affected by nearby dipoles.

Typically, the dipole lengths vary over the range of 0.25 to 0.60 wavelengths to achieve a full 360° range of phase shifts. The ideal spacing between the ground-plane and the dipole is $1/16$ to $1/8$ wavelength. The spacing affects form-factor, bandwidth, and sensitivity to fabrication tolerances.

ELECTRICAL DESIGN FEATURES

Linear Array of FLAPS™ Elements

The FLAPS™ elemental scatterer performs the function of a radiating element and a phase shifter in a space fed phased array. Since dipoles of different lengths will produce a phase shift in the incident wave, arranging the distribution and the lengths of the dipoles will serve to steer, focus or shape the reflected wave. As the above figure illustrates, an array of such elements is designed to reradiate with a progressive series of phase shifts so that an RF beam is formed in a specific direction.

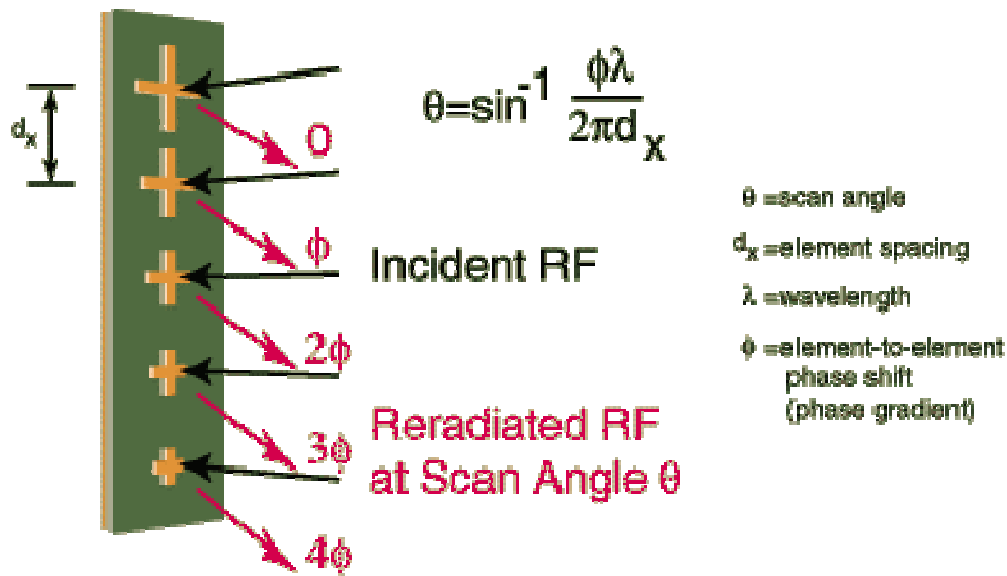

Microwave FLAPS™ Antenna

In a simple application, a parabolic surface can be directly replaced with a FLAPS™. It is possible to design a FLAPS™ as a substitute for any conventional reflector used in antenna design.

FLAPS™ surfaces can be up to 95% efficient. When designed as an offset reflector, the feed may be offset up to 60° from the flat surface. Bandwidths of 3% to 10% are achievable with a designed center frequency in the range from 1 to 100 GHz.

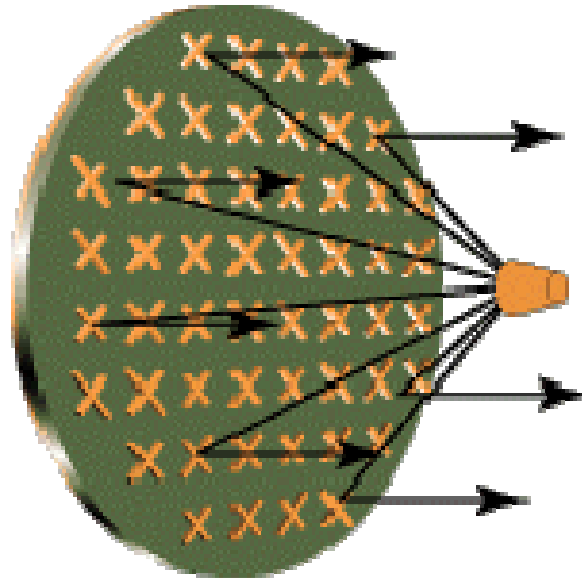

POLARIZATION CONVERSION AND ROTATION

Typically, at the element level of a standard FLAPS™ design, the orthogonal dipoles are designed to reflect with the same phase shift relative to each other. When designed in this manner, the FLAPS™ surface will function as a standard metal reflector and have no influence on the reflected polarization. Therefore, the antenna polarization will be determined by the feed design.

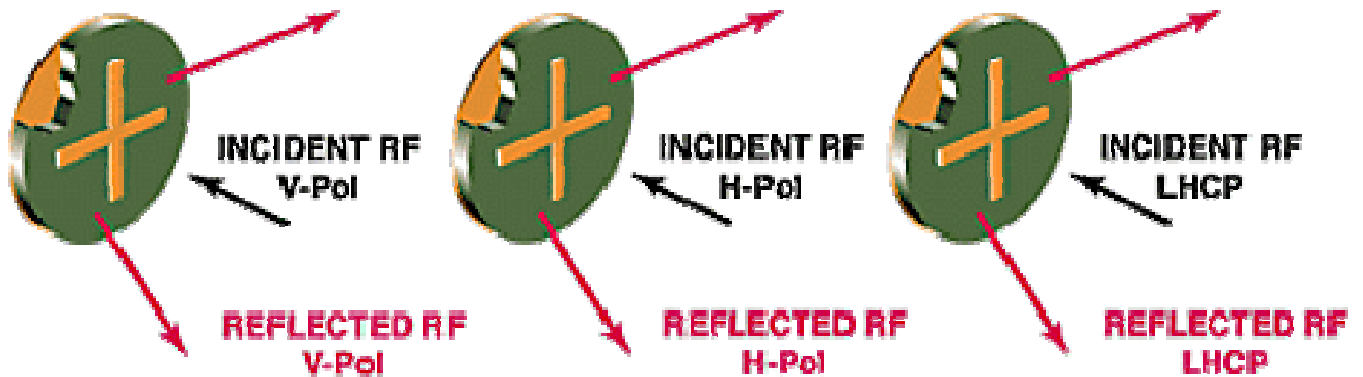

FLAPS™ Elements Designed to Convert Linear to Circular Polarization

The polarization isolation between the orthogonal dipoles is very high (greater than 50 dB). This valuable feature allows independent control of the separate eigenvectors of the RF energy reflecting off the FLAPS™.

Designing the orthogonal dipoles to reradiate with a 90° relative phase shift will result in a surface that will convert 45° linear incident RF into circular polarization. In fact, a surface designed in this manner will yield left and right hand circular as well as horizontal and vertical linear polarizations with a single linear polarized feed depending upon the relative polarization orientation of the feed. This eliminates the requirement for a costly circular polarized feed.

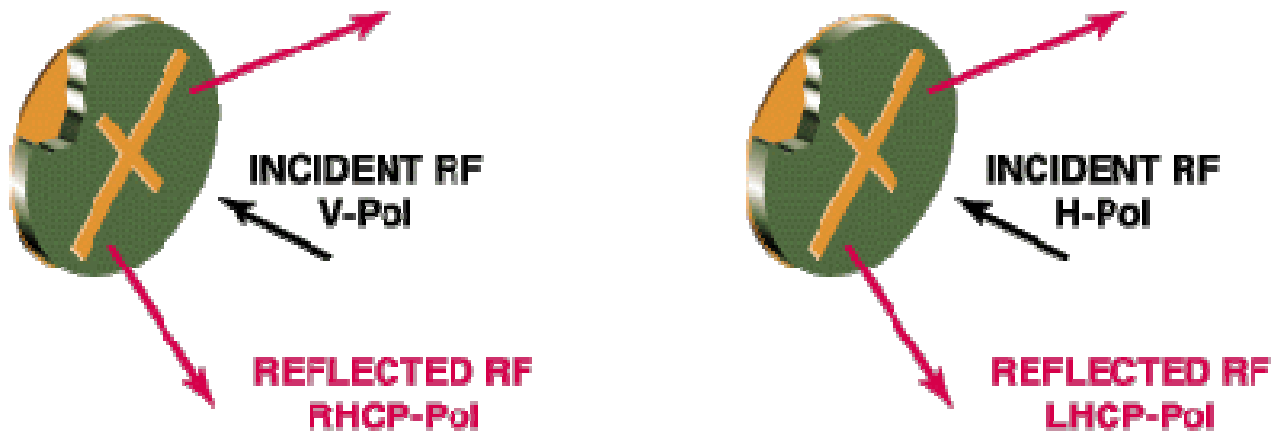

FLAPS™ Elements Designed to Rotate Polarization 90°

in similar fashion, a FLAPS™ surface could be designed to convert horizontal linear to vertical linear. Using this feature with a parallel-wire-grid subreflector, a "twist-Cassegrain" antenna is possible whereby the linear polarized feed energy reflected back from the wire grid subreflector will be columnated and rotated 90° by the FLAPS™ surface and passed through the subreflector, thus eliminating the blockage effects normally associated with the subreflector

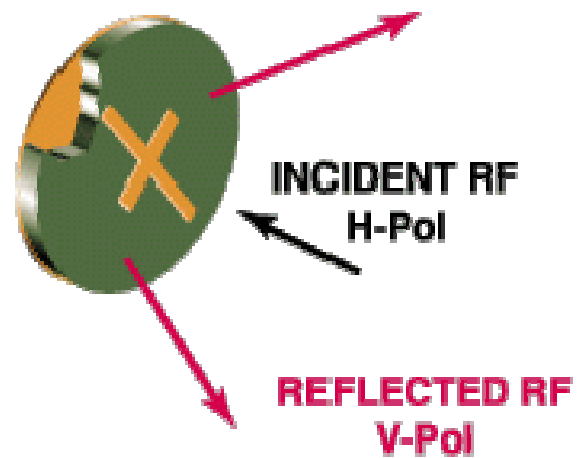
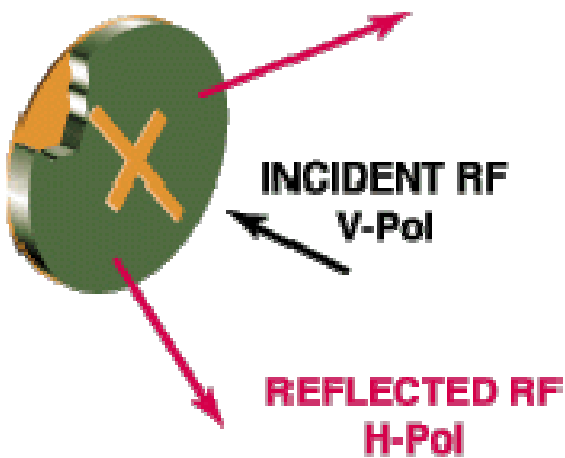

POLARIZATION ISOLATION

FLAPS™ Antenna Having Two different Beam Characteristics at Orthogonal Linear Polarizations

FLAPS™ technology allows the designer to independently control the RF reflecting characteristics of the FLAPS™ for orthogonal senses of polarization. This capability eases the design of an antenna system that requires dual linear polarization. By designing the FLAPS™ surface to have separate focal points for the orthogonal linear polarizations, a dual polarized feed is not required. This technique will also result in high polarization isolation. It is also interesting to note that this feature allows two independent beam characteristics to be achieved at orthogonal linear polarizations. For example, the FLAPS™ surface can be designed to achieve a pencil beam at vertical polarization and a shaped beam at horizontal polarization

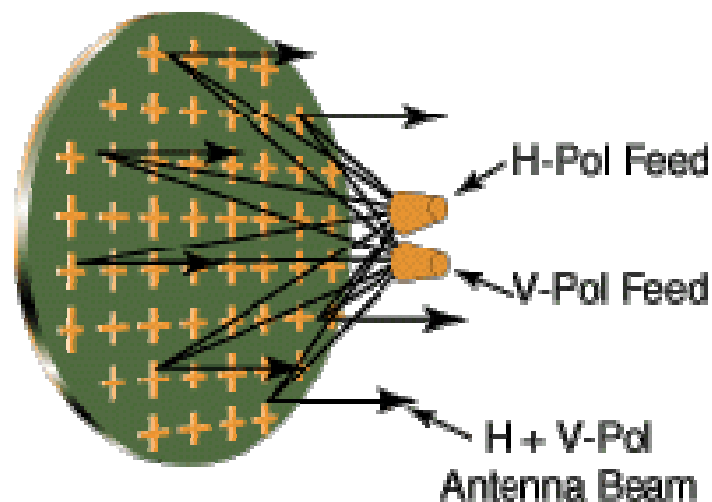

RF TRANSPARENT FLAPS™ FOR DUAL FREQUENCY APPLICATIONS

Substituting the Solid Groundplane with a Resonant Dipole Array Results in a FLAPS™ Reflector that is Transparent to RF That is not in the Design Band

In all the examples reviewed so far, the dipoles are suspended in front of a solid metal ground plane. By substituting the solid ground plane of a FLAPS™ reflector with an array of dipoles that are at resonance at the frequency of design, the FLAPS™ reflector has the additional feature of being RF transparent at other frequencies as illustrated above. Antennas designed in this fashion can be placed in front of a planar array for dual frequency applications. This technique is well suited to modifying existing airborne weather radar antenna systems with a millimeter wave aperture for landing radar and obstacle avoidance applications. Antennas built in the fashion also exhibit low radar cross section features.

Layered FLAPS™ reflectors can also be designed to operate at two or more frequencies. In a MILSTAR application, for example, a transparent FLAPS™ is designed to operate at 44 GHz and placed directly in front of another FLAPS™ designed to operate at 20 GHz. In this example, the antenna feed is greatly simplified by designing separate focal points for each frequency and using separate feeds in lieu of one costly dual frequency feed. Considerable freedom is allowed in the design of the feed locations.

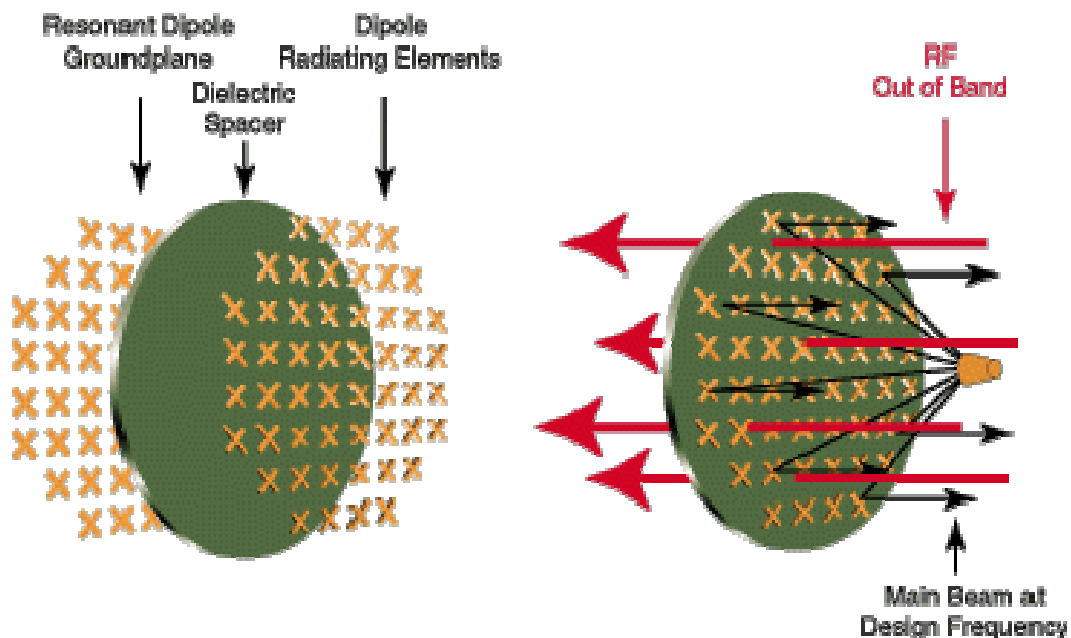

CONFORMAL FLAPS™

FLAPS™ Reflectors May be Conformal as Well as Planar

Nearly any geometrically shaped surface can be "electromagnetically reshaped" with FLAPS™ technology to yield the desired reflection pattern characteristics. In difficult site environments the surface of a building, fence, or parking lot, for example, can function as the FLAPS™ reflector of a fixed satellite earth station antenna even though it is not normal to the direction of the satellite of interest. Furthermore, the ability to design the FLAPS™ so the feed may be at any defined location with respect to the FLAPS™ greatly simplifies the antenna design.

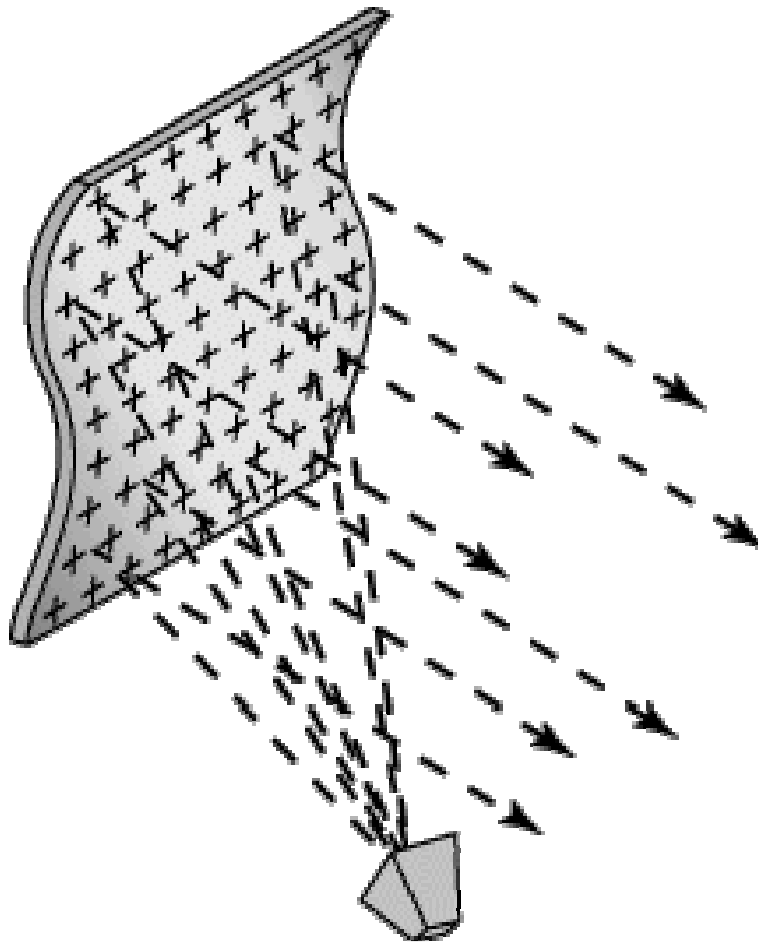

LOW-COST BEAM SCANNING OR SWITCHING

Wide Angle Beam Scanning Using a Non-Parabolic Curved FLAPS™ Reflector.

Typically, the beam of a conventional parabolic reflector is repositioned by moving the feed and the reflector via a gimbal mechanism. By using a unique non-parabolic shaped reflector that is "phase corrected" with FLAPS™ technology, however, it is possible to redirect the beam as much as 90° by moving only the FLAPS™ reflector and keeping the feed fixed. This eliminates the need for a rotary joint and greatly reduces the mass that must be moved. The 2:1 scan effect also reduces the swept volume of the reflector for a given required scan angle.

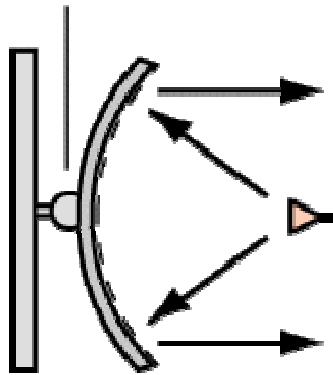

TILT FLAPS™
Beam at Boresight

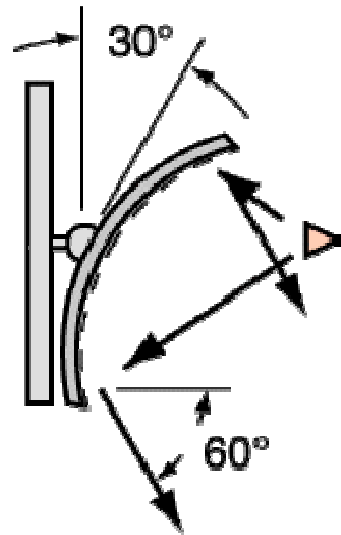

TILT FLAPS™
Beam Scan via
Tilting Reflector

A Non-Parabolic Curved FLAPS™ Reflector Designed to Beam Scan With Repositioning of the Feed Location

Alternately, by placing several feeds at different locations in front of a common "curved" FLAPS™ surface, antenna beams can be directed to different locations. These can be simultaneous beams, or rapidly switched, whichever the application requires. TILT FLAPS™ Technology is suitable for a high gain digital link antennas that must communicate with several other links, multibeam antennas and millimeter-wave cameras

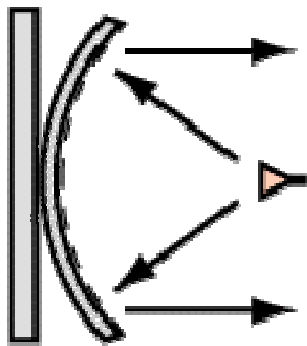

TILT FLAPS™
Beam at Boresight

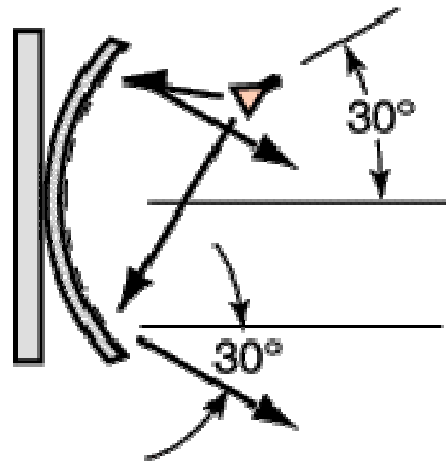

TILT FLAPS™
Beam Scan via
Moving (Switching) Feed

MECHANICAL DESIGN FEATURES

FLAPS™ surfaces can be fabricated in a variety of ways. The only mechanical requirement is to support the double-layer of dipoles with the desired spacing between layers and between dipoles, and with adequate mechanical integrity to maintain the spacing and surface shape under the anticipated operating loads. For most ground-based and airborne defense applications to date, FLAPS™ surfaces have been etched from double-layer printed-circuit boards. These surfaces readily produce the required surface shape (e.g. flatness) and surface smoothness, even at 94 GHz. FLAPS™ technology lends itself readily to low-cost CAD/CAM fabrication. Very low-cost FLAPS™ surfaces intended for direct-broadcast consumer TV reception have been produced by silk-screening onto plastic panels.

Very low mass FLAPS™ surfaces are possible, since the dielectric layer can be lightened considerably. Designs based on lightened-foam-plastic dielectric layers with the dipoles deposited on thin Kapton films result in reflector masses as low as 0.05 to 0.1 kg/m², not including the supporting structure.

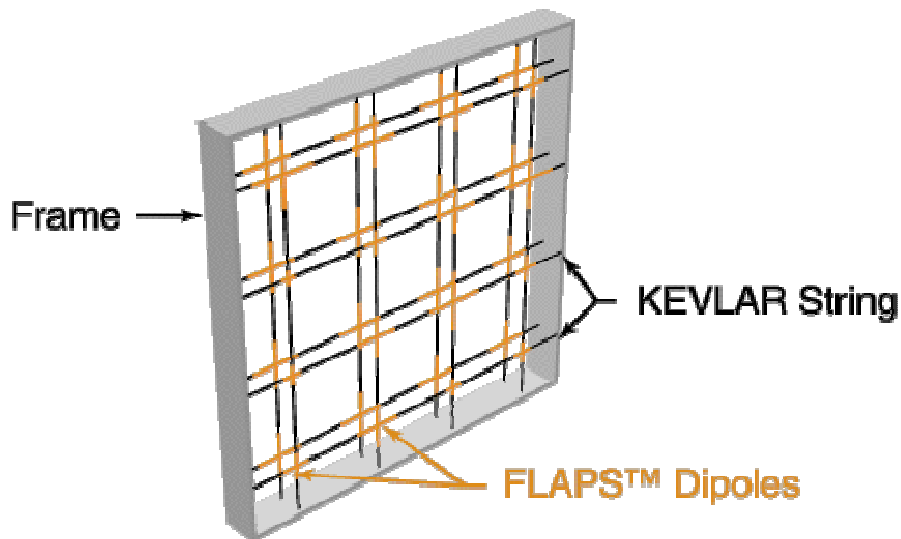

LARGE APERTURES WITH LOW WINDLOAD

FLAPS™ Apertures Fabricated using KEVLAR String to Support the Dipoles Experience Very-Low Windloads, Thus Easing the Weight and Capacity of the Antenna Support Structure

Most satellite earth stations must operate in high winds. As the apertures get larger, the windload forces require costly mounting supports and tracking systems. At approximately 8 GHz and below, light weight FLAPS™ surfaces can be fabricated that exhibit as little as 1/8 the windloading forces of conventional solid or wire-mesh reflectors. This is achieved by fabricating a frame and attaching KEVLAR string in "tennis racket" fashion, with a grid spacing of about 0.5 wavelength. Dipoles are then attached on the string. The groundplane surface is fabricated in the same manner to complete a FLAPS™ surface as illustrated. This fabrication technique significantly reduces the mounting and positioning requirements, which results in a much lower-cost antenna system. Recently, a 20-foot C-band antenna system has been developed. This antenna system is designed for rapid deployment and is capable of withstanding winds of 70 mph. This fabrication technique is also applicable to large aperture air traffic control radar applications. See product photos for examples of products delivered using this feature.

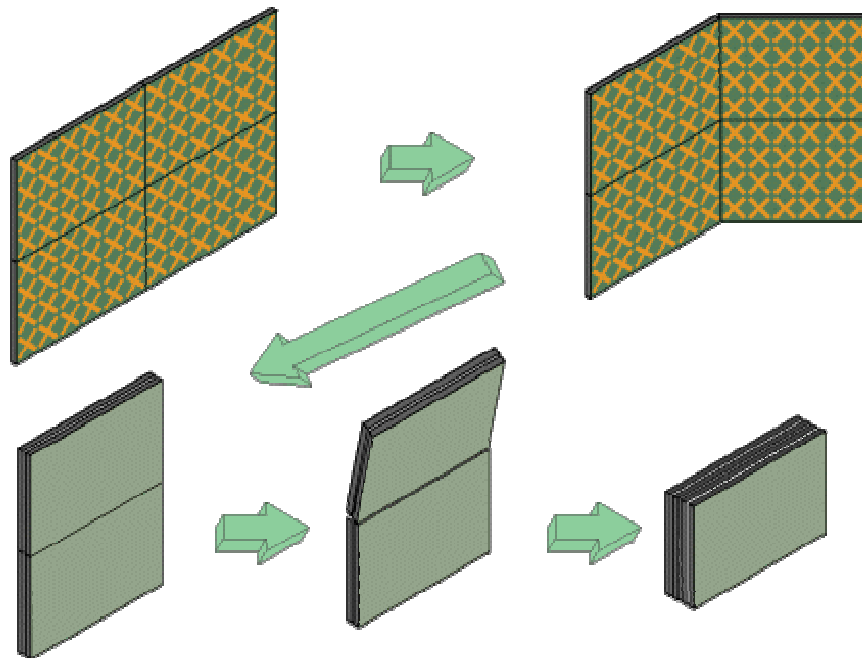

Planar FLAPS™ Surfaces Easily Fold, Stow and Deploy



LARGE PORTABLE APERTURES

Conventional reflector antenna systems usually are difficult to disassemble and package for portable and rapid deployment applications. Even when sectioned, the curved reflector panels do not store efficiently.

Thin, planar FLAPS™ reflectors, however, are efficiently stowed in compact packages and deployed via a simple hinging or assembly process. A very simple hinge-folding scheme is illustrated. One such antenna has been developed for a commercial INMARSAT-B terminal. Another novel folding scheme was used for a MILSTAR antenna

SUMMARY

FLAPS™ reflectors can be configured in many different ways. Packaging and deployment are limited mainly by the imagination of the designer. FLAPS™ surfaces do not have to be planar and they do not have to be continuous. Small sections are easily fabricated and later "tiled" to complete the full aperture. When fabricated in this manner, electrical continuity is not a requirement. Provided the antenna designer knows, in advance, the beam location and shape, the feed location, and the reflector surface geometry, FLAPS™ technology can be used to electrically reshape the surface to perform as a parabola. Conventional reflector antenna calculations apply to determine surface tolerances, gain, sidelobes, and other electrical antenna parameters.

FLAPS™ reflector antenna technology is a proven candidate for low-cost commercial applications. It has been fielded in a variety of defense radar and communications applications and provides many features preferred by commercial systems.

These features include lightweight low-wind loading simple deployment packaging ease polarization control low recurring costs. Product examples and photos of FLAPS™ antennas are available for review from CPI Malibu Division web. For additional information directly to obtain more detailed information or to discuss a specific requirement contact:

Mr Anthony J. Macari

Director Business Development, Advanced Antennas

(805) 383 1829 x108; mobile (805) 490 1947