

Integrated Microwave Assemblies

Receiver Front End Assembly

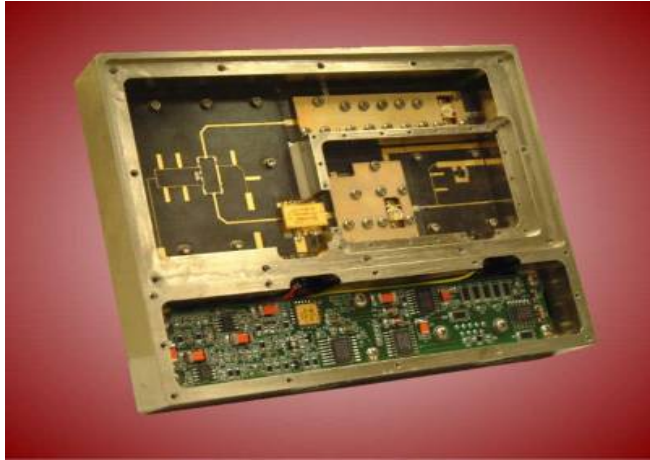

X-Band Front End

Description:

CPI's Beverly Microwave Division has the technical capability and experience to design and manufacture microwave integrated circuit assemblies. A typical example of a receiver front end is shown above.

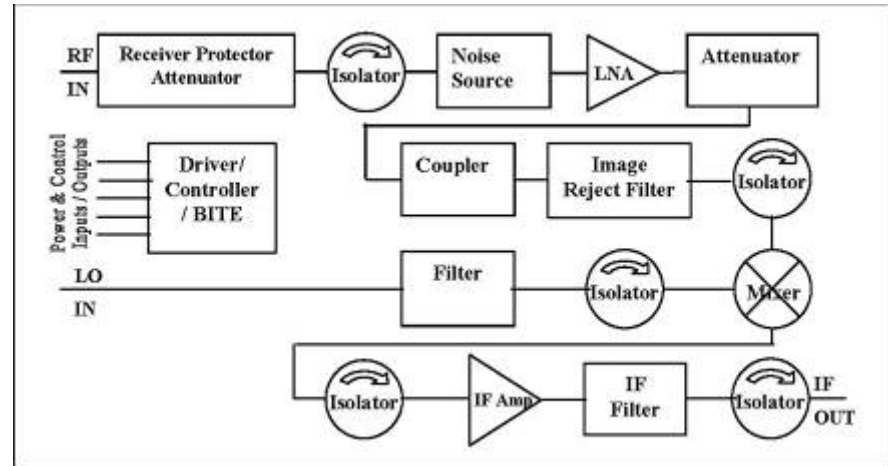

Features:

- Our capability extends up to 40 GHz.
- Power handling capability using traditional integrated circuit techniques can be as high as 10 kW peak.
- This can be extended to megawatt power levels when other technologies are incorporated into the design.

150 Sohier Road
Beverly, Massachusetts



Beverly Microwave Division

Phone: 978-922-6000 Fax: 978-922-2736
E-Mail: marketing@bmd.cpii.com
Internet: www.cpii.com/bmd