

INTRODUCTION

These Operating Instructions provide basic information for installing and operating CPI MPP's 5100 Series and 5200 Series of high-power pulsed helix vacuum electron devices (traditionally known as helix traveling-wave tubes, or TWTs). Supplementary information is given in the individual Test Performance Sheet, Product Specification, and the product outline drawing. The Test Performance Sheet, which is shipped with the product, contains characteristics and operating values for the individual unit. Inquiries for additional information and requests for copies of these publications should be made to:

**Manager, Marketing
Communications & Power Industries, Inc. (CPI)
MICROWAVE POWER PRODUCTS DIVISION
811 Hansen Way
Palo Alto, CA 94303
Telephone: (650) 846-3900**

For more detailed product operating procedures in specific equipment, consult the applicable equipment manuals and equipment performance standards. Additional information may be obtained from the equipment manufacturer. Some operational details specified by the equipment manufacturer may vary from those given herein.

WARNING

SERIOUS HAZARDS EXIST IN THE OPERATION OF MICROWAVE DEVICES. BEFORE ATTEMPTING ANY PRODUCT OPERATION, CAREFULLY READ AND UNDERSTAND THE "OPERATING HAZARDS" SECTION FOLLOWING THESE OPERATING INSTRUCTIONS, AS WELL AS THESE INSTALLATION AND OPERATING INSTRUCTIONS. A COPY OF "OPERATING HAZARDS" IS ALSO SHIPPED WITH EACH PRODUCT.

SPECIFIC HAZARDS

CPI as a component supplier can assume no responsibility for any damage or injury resulting from operation of CPI products. These devices must be used with equipment designed to protect personnel against all operating hazards. Installation and operating precautions should be observed, and ratings given in the Test Performance Sheet must not be exceeded.

High Voltage — *Normal operating voltages are deadly.* The equipment must be designed so the operator cannot come into contact with high voltages. High-voltage circuits and terminals must be enclosed, and interlocking switch circuits must be maintained so they open the primary circuits of the power supply and discharge high-voltage capacitors when access is required.

RF Radiation — *Exposure to rf radiation generated by this device during operation may cause serious bodily injury, possibly resulting in blindness or death.* Cardiac pacemakers may be affected. Exposure of the human body to microwave radiation in excess of 10 milliwatts per square centimeter can be harmful. For this reason, rf energy must be contained by the waveguides and shielding. If voltages are to be applied when the device is not connected into a waveguide system, the rf input and output flanges should be closed tightly with shielded terminations.

Beryllium Oxide (BeO) — Some of these product types utilize beryllium-oxide parts. The dust and fumes from beryllium oxide are highly toxic and can cause serious injury or death. Those devices containing beryllium oxide are so labeled.

Elevated Temperatures — External surfaces of those product types that are conduction cooled will attain temperatures in the 100°–200°C range during operation, notably in the collector region. Avoid physical contact for a sufficient period after operation is terminated to permit adequate cooling. The water used to cool the collector reaches scalding temperatures. Touching or rupture of the cooling system can cause serious burns.

These hazards are specifically described in the Operating Hazards section immediately following these operating instructions. Equipment using these devices must be designed to minimize risk to personnel from these hazards. Equipment manufacturers and users must develop and institute procedures suitable for the particular equipment and specific use to guard against all hazards not eliminated through equipment design.

HANDLING

The product is shipped in an approved package that will protect it from moderate handling abuse. If the outer container shows evidence of being dropped or is punctured, open the package and inspect the unit for damage. Inspect the product when it is removed from the container. If any obvious defects appear, a report should be sent to the factory at once.

Any damage during shipment should be reported to the carrier. Handle the device with care during unpacking and installation. Exercise particular caution to prevent any damage to the mounting surface of conduction-cooled devices, since such damage may restrict heat transfer during operation.

PROTECTIVE MEASURES

These devices must be used in equipment that provides automatic protection as described below. In addition, installation and operating precautions must be observed, and ratings shown within the Test Performance Sheet must not be exceeded under continuous or transient conditions. A single rating may be the limitation, and simultaneous operation at more than one rating may not be possible. Failure to comply fully with the foregoing may result in product failure, damage, or decreased operating life. Any product damage or failure resulting from noncompliance with these requirements or which, in CPI's opinion, could have been avoided by compliance with these requirements will void the CPI warranty.

Heater Voltage — Either an ac or dc heater supply may be used unless otherwise specified on the Test Performance Sheet. In some cases, an ac heater voltage will damage the device. If an ac heater supply is used, there is no limitation on the frequency of the voltage. However, for minimum heater modulation, a direct-current heater supply may be used. If a dc heater supply is used, the yellow lead *must* connect to the positive side of the heater supply (see Figure 1). Product life will be greatly reduced if the heater polarity is reversed. Moreover, heater surge current should *never* exceed approximately two and one-half times the steady-state value.

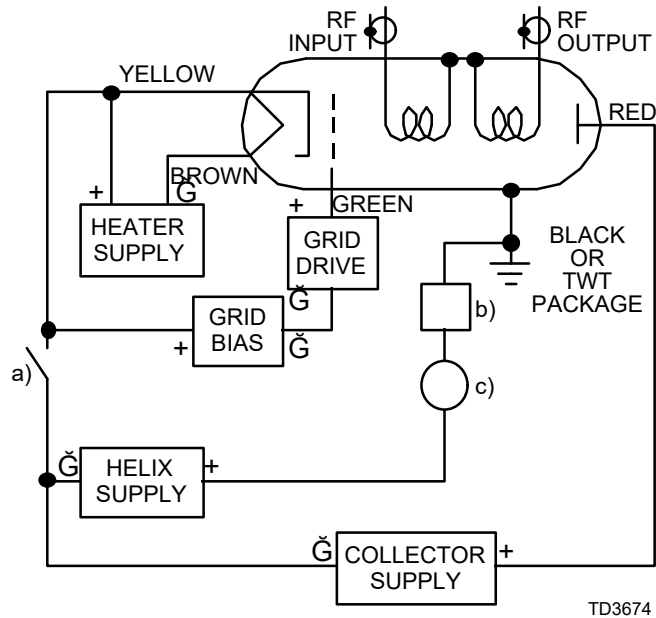

FIGURE 1.
TYPICAL POWER-SUPPLY CIRCUIT

Helix (Body) Current — An overcurrent relay (as depicted in Figure 1) should be part of the power supply and should

remove the helix voltage (sometimes referred to as beam or cathode voltage) in a fraction of a second if the TWT body current exceeds the specified value. The relay trip level should be adjusted to 130 percent of the maximum current encountered in system operation or to a value just below the absolute maximum rating, whichever is lower.

Power-Supply Insulation — Since the TWT body operates at ground potential, the heater supply must be insulated to withstand the full beam voltage.

Cathode Current Delay — Voltages that initiate cathode current flow should never be applied to the device until the cathode has reached full operating temperature. The cathode is raised to operating temperature by applying heater voltage. A time-delay relay in the power supply should prevent the application of other voltages until the specified time after the heater is turned on, or as defined by the individual Product Specification. Refer to the "Operation" section of these Operating Instructions.

Bias Voltage Interlock — A protective circuit to prevent the application of grid high voltages without grid bias is recommended.

Thermal Switch — Most of these devices are equipped with an integral thermal switch that should be connected to the power supply such that the device is turned off if the switch activates. The designated operating (trip) temperature of these switches is somewhat above the maximum continuous operating temperature for each product type. Both normally closed and normally open switches are used; see the specific Product Specification. Because the thermal switch is intended to protect the device in case of cooling-equipment failure, absence of thermal-switch operation is not an indicator of adequate cooling.

Cooling —

Conduction-Cooled Types. The most effective cooling for these devices is provided by a liquid-cooled heat-exchanger plate. Because conduction cooling is achieved through the base plate, it must be tightly fastened to a heat sink whose maximum temperature does not exceed the maximum allowable temperature defined by the individual Product Specification. A finned heat exchanger bolted to the base plate can be used to cool these TWTs, but this method only provides adequate cooling in limited applications (those where the maximum inlet air temperature is not greater than 40°C, the altitude is near sea level, and collector dissipation is no greater than 1 kilowatt). Under these conditions, a finned heat exchanger with high fin density (as in a brazed assembly) is required. The exchanger must be compact and placed directly under the TWT collector area. Heat exchangers using extruded aluminum fins are generally inadequate.

Air-Cooled Types. Air-cooled types have passageways within the TWT package that allow air to be ducted from an external blower. The blower chosen should be able to supply the air flow in accordance with the requirements given in the individual Product Specification at the total back-pressure of

the TWT, plus that of ducting and filters used with the equipment.

Whether liquid or air cooled, the mounting surface of the heat sink must be machined smooth and flat to ensure maximum contact area with the TWT base plate. The heat transfer to the heat sink is improved by using a thin layer of high-conductivity grease, such as Wakefield Thermal Compound No. 120-8, or equivalent. The amount of compound used should be just sufficient to fill any voids between the two surfaces when they are bolted together and not increase the spacing between the surfaces.

CAUTION

THE USE OF AN EXCESSIVE AMOUNT OF THERMAL COMPOUND MAY RESULT IN OVERHEATING AND CAUSE DAMAGE TO THE TWT.

VSWR — The VSWR of the drive source and output load must not exceed the value specified on the Product Specification throughout the operating frequency range. Low-pass reactive filters must be used to filter out the second harmonic without damage to the TWT, provided the rf drive frequency is always within the filter passband.

RF Leakage — External leakage should be prevented by making tight rf input and output connections. Under certain tuning conditions, regeneration or oscillation can occur if rf energy from the output line or radiation from the antenna reaches the input cavity because of faulty rf connections, leaky cable, or inadequate shielding. RF radiation is hazardous. See Operating Hazards section.

Permanent Magnet — The beam is focused by a permanent magnet. The TWT and magnet are held together by bolts that should never be loosened. The magnet field strength is very high and must be maintained to ensure proper product operation. Disturbance of the magnetic field from external sources may seriously affect product performance and, in extreme cases, may destroy the device.

CAUTION

THE DEVICE SHOULD NOT BE INSTALLED IN REGIONS OF STRONG MAGNETIC FIELDS, EITHER STATIC OR ALTERNATING. SUCH FIELDS MAY DEFOCUS THE TWT OR CAUSE SPURIOUS MODULATION OF THE RF OUTPUT AND, IN EXTREME CASES, MAY DESTROY THE DEVICE. POWER-SUPPLY TRANSFORMERS ARE A LIKELY SOURCE OF STRAY MAGNETIC FIELDS.

OPERATION

WARNING

DO NOT ATTEMPT TO OPERATE THIS DEVICE UNTIL IT HAS BEEN DETERMINED THAT ALL PRECAUTIONS HAVE BEEN TAKEN TO PROTECT PERSONNEL FROM ALL HAZARDS. PROTECTIVE DEVICES SUCH AS SHIELDS AND INTERLOCKING SWITCH CIRCUITS MUST BE IN OPERATION. REREAD AND COMPLY WITH ALL PRECAUTIONS AND PROCEDURES SPECIFIED IN THE "OPERATING HAZARDS" SECTION.

Preliminary Check — Check the following conditions before applying voltages to the device:

1. Heater, cathode, control anode, grid, collector, and rf connections are made correctly.

WARNING

RF RADIATION — THIS DEVICE IS DESIGNED TO PRODUCE HIGH-ENERGY RF RADIATION. EVEN LOW LEVELS OF RF RADIATION CAN BE HAZARDOUS TO HUMAN HEALTH. PRECAUTIONS MUST BE TAKEN TO PREVENT EXPOSURE OF PERSONNEL TO THE STRONG RF FIELDS GENERATED BY THIS DEVICE. RF RADIATION DUE TO LEAKAGE AT THE WAVEGUIDE FLANGE SHOULD BE PREVENTED BY MAKING TIGHT RF INLET AND OUTPUT CONNECTIONS. NEVER OPERATE THIS DEVICE WITHOUT HAVING AN APPROPRIATE ENERGY-ABSORBING LOAD ATTACHED. NEVER LOOK INTO AN OPEN WAVEGUIDE OR ANTENNA WHILE THIS DEVICE IS ENERGIZED.

2. TWT body is grounded (lead-wire color is indicated on the product nameplate).
3. All protective circuits are operational.
4. All specified cooling circuits are operational.

Application of Voltages — Recommended operating voltages and currents are given on the product nameplate and are to be applied in the following sequence (see Figure 1):

- a. Optional high-voltage vacuum relay
- b. Helix overcurrent sensor
- c. Optional helix current meter (use meter protector)

WARNING

HIGH VOLTAGE — VOLTAGES REQUIRED FOR OPERATION OF THIS DEVICE ARE EXTREMELY DANGEROUS TO LIFE; EQUIPMENT MUST BE DESIGNED WITH PROTECTIVE INTERLOCK CIRCUITS TO MAKE PHYSICAL CONTACT WITH THESE VOLTAGES IMPOSSIBLE. SEE "OPERATING HAZARDS" SECTION.

1. **Heater Voltage.** Turn on the heater power supply, and adjust the voltage to the value indicated on the Test Performance Sheet. Allow the specified time for the cathode to reach its operating temperature. Note that the cathode resistance will change during this period, and the supply voltage requires readjusting.
2. **Bias Voltage.** Turn on the bias supply, and adjust the voltage to the value indicated on the Test Performance Sheet. Take care to ensure that there is never any loss or droop in the bias supply during operation. Bias voltage may be applied simultaneously with the heater voltage.
3. **Cathode Voltage and Collector Voltage.** Turn on the high-voltage supplies, and adjust to the values indicated on the Test Performance Sheet.

4. **Grid-Pulse Voltage.** With the grid supply set to a suitable pulse length and duty cycle, the grid voltage should be switched on at the value indicated on the Test Performance Sheet. Note that the peak grid pulse voltage is measured relative to cathode potential so that the total grid pulse-up voltage from the bias is the sum of the bias and peak grid pulse voltages.

CAUTION

TO PREVENT SERIOUS DAMAGE TO THE DEVICE, NEVER APPLY THE CATHODE VOLTAGE OR GRID-PULSE VOLTAGE BEFORE THE GRID-BIAS VOLTAGE, AND NEVER APPLY THE GRID-PULSE VOLTAGE BEFORE THE CATHODE VOLTAGE

NOTE

It is preferable to lower the pulse duty cycle prior to making adjustments in cathode, collector, or grid pulse voltages.

Power-supply loading may cause high-voltage values to drop during pulse-on conditions.

5. **Removal of Voltages.** Voltages shall be removed in the reverse order of application.
6. **Voltage Adjustment, Regulation, and Ripple.** The helix voltage supply must be adjustable over the range specified in the Product Specification to accommodate all TWTs supplied to that specification. For any individual TWT, the helix voltage must be set to the value given on the nameplate label with an accuracy of ± 0.25 percent or better to obtain performance reasonably close to that given on the Test Performance Sheet. The collector voltage need not be adjustable but must remain within the operating range given in the Product Specification.

The regulation and ripple requirements for the helix supply are critical. They are determined by the TWT's phase and amplitude sensitivity to helix voltage and the requirements of the application. Phase and amplitude

sensitivity values are given in the Product Specification for some of these product types. For the others, approximate values of 2 degrees and 0.03 dB per volt may be used as a guide. These values are not specifications.

Collector supply regulations and ripple requirements are much less critical. The basic requirement is that the voltage remain between the specified limits under all conditions of load, line, and environment. Note that this requirement includes the instantaneous voltage resulting from the superimposed ripple voltage.

7. **RF Drive.** RF drive should be initially applied at a low level, then raised to the values indicated on the Test Performance Sheet.

RETURNED PRODUCT FORM

Before any product is returned for repair and/or adjustment, written authorization from CPI for the return and instructions as to how and where the product should be shipped must be obtained. The product type and serial numbers and a full description of the circumstances giving rise to the warranty claim should be included. Such information will help establish the cause of failure and expedite adjustment or repair. For this purpose, a Returned Product Form is shipped with each product.

TRANSPORTATION AND STORAGE

Use the original packing case for both transportation and storage of the product when it is not in service. If it is necessary to store the device outside of the container, the device should be placed with its mounting surface on a smooth, flat surface.

CAUTION

PRODUCT STORAGE SHELVES MUST BE MADE OF NONMAGNETIC MATERIALS.