

## Communications & Power Industries Tetrode



The EIMAC 4CX20,000C is a ceramic/metal power tetrode intended for use as a VHF power amplifier. It features a type of internal mechanical structure which results in high rf operating efficiency. Low rf losses in this structure permit operation at full ratings to 110 MHz.

The 4CX20,000C provides high gain in FM broadcast service and is also recommended for rf linear power amplifier service. The anode is rated for 20 kilowatts of dissipation with forced-air cooling and incorporates a compact, highly efficient cooler of new design.

### FEATURES:

#### Electrical:

Filament: Thoriated Tungsten Mesh	
Voltage	10.0±0.5 V
Current at 10.0 Volts	140 A
Amplification factor, average, grid to screen	6.7
Direct interelectrode capacitances (grounded cathode) <sup>2</sup> :	
C <sub>in</sub>	195 pf
C <sub>out</sub>	22.7 pf
C <sub>gp</sub>	0.6 pf
Direct interelectrode capacitances (grounded grid and screen) <sup>2</sup> :	
C <sub>in</sub>	87.4 pf
C <sub>out</sub>	23.1 pf
C <sub>PK</sub>	0.8 pf
Maximum frequency for full ratings (CW)	110 MHz

### BENEFITS:

- Worldwide brand name recognition
- Over 85 years technical expertise

#### Mechanical:

Maximum overall dimensions:	
Length	9.84 in/249.9 mm
Diameter	8.86 in/225.0 mm
Net weight	20.0 lbs/9.06 kg
Operating position	Vertical, base up or down
Maximum operating temperature:	
Ceramic/Metal seals	250°C
Anode core	250°C
Cooling	Forced air
Base	Special, coaxial
Recommended socket for VHF	Eimac SK-360
Recommended socket for dc to HF	Eimac SK-320
Available anode contact connector clip	Eimac ACC-3

### APPLICATIONS:

- Communications

## Communications & Power Industries Tetrode

### Radio frequency power amplifier cathode grounded

FM continuous service  
Grid Driven Class C

#### Absolute maximum ratings:

DC anode voltage	13.0 kV
DC screen voltage	2.0 kV
DC grid voltage	-1.5 kV
DC anode current	5.0 A
Anode dissipation	20 kW
Screen dissipation	450 W
Grid dissipation	200 W

### Radio frequency power amplifier grid grounded for RF

FM continuous service  
Cathode driven Class B

#### Absolute maximum ratings:

DC anode voltage	13.0 kV
DC screen voltage	2.0 kV
DC grid voltage	-1.5 kV
DC anode current	5.0 A
Anode dissipation	20 kW
Screen dissipation	450 W
Grid dissipation	200 W

#### Typical operation (measured data at 107.1 MHz):

Anode voltage	9.0	11.5	12.0	kVdc
Screen voltage	800	650	1000	Vdc
Grid voltage	-300	-400	-500	Vdc
Anode current	4.15	3.75	3.54	Adc
Screen current*	200	160	238	mAdc
Grid current*	38	60	53	mAdc
Driving power*	360	405	340	W
Useful power output*#	28.9	33.2	34.4	kW
Efficiency*	77.4	77.6	81.0	%
Power gain*	19.0	19.1	20.0	dB

\*Will vary from tube to tube

#Delivered to load (1:1.1 VSWR)

#### Typical operation (measured data at 97.6 MHz):

Anode voltage	11.0	kVdc
Screen voltage	900	Vdc
Grid bias voltage	-200	Vdc
Anode current	4.1	Adc
Screen current*	235	mAdc
Grid current*	30	mAdc
Driving power*	1025	W
Anode power input	45.1	kW
Useful power output*#	36.1	kW
Power gain*	15.5	dB

\*Will vary from tube to tube

#Delivered to load (1:1.1 VSWR)

NOTE: TYPICAL OPERATION data are obtained by actual measurement or by calculation from published characteristic curves. To obtain the anode current shown at the specified bias, screen and anode voltages, adjustment of rf grid voltage is assumed. If this procedure is followed, there will be little variation in output power when the tube is replaced, even though there may be some variation in grid and screen currents. The grid and screen currents which occur when the desired anode current is obtained are incidental and vary from tube to tube. These current variations cause no performance degradation providing the circuit maintains the correct voltage in the presence of the current variations.

#### Range values for equipment design

	Minimum	Nominal	Maximum
Filament current at 10.0 volts	135	---	146

## Communications & Power Industries Tetrode

### Mechanical

**STORAGE** - If a tube is to be stored as a spare it should be kept in its original shipping carton, with the original packing material, to minimize the possibility of handling damage.

**MOUNTING** - The 4CX20,000C must be operated with its axis vertical. The base of the tube may be up or down at the convenience of the designer.

**SOCKET** - The EIMAC Air-System Socket type SK-320 is designed for use with the 4CX20,000C in dc or LF/HF applications. For VHF applications a type SK-360 air-system socket is recommended. The use of the recommended air flow through an air-system socket will provide effective cooling of the base.

**COOLING** - The maximum temperature rating for the external surfaces of this tube is 250°C, and sufficient forced-air cooling must be used in all applications to keep the temperature of the anode (at the base of the cooling fins) and the temperature of the ceramic/metal seals comfortably below this rated maximum.

It is considered good engineering practice to design for a maximum anode core temperature of 225°C. Temperature-sensitive paints are available for checking base and seal temperatures before any design is finalized. CPI EIMAC Application Bulletin #20 titled "Measuring Temperature of Power Grid Tubes" is available on request.

It is also good practice to allow for variables such as dirty air filters, rf seal heating, and the fact that the anode cooling fins may not be clean if the tube has been in service for a considerable length of time. Special attention is required in cooling the center of the stem (base), by means of special directors or some other provision.

An air interlock system should be incorporated in the design to automatically remove all voltages from the tube in case of even partial failure of the tube cooling air. Sensing exhaust air temperature is recommended.

Minimum air flow requirements for a maximum anode temperature of 225°C (or a maximum outlet air temperature of 160°C, whichever is reached first) for various altitudes and dissipation levels are listed on page 4. Pressure drop values are approximate and are for the tube anode cooler only. Pressure drop in a typical installation will be higher because of system loss and back pressure in ducting.

When long life and consistent performance are factors cooling in excess of minimum requirements is normally beneficial.

If all cooling air is not passed around the base of the tube and through the socket, then arrangements must be made to assure adequate cooling of the tube base and the socket contacts. Movement of cooling air around the base of the tube accomplishes a double purpose in keeping the tube base and the socket contact fingers at a safe operating temperature.

The contact fingers in the socket are made of beryllium copper. If this material is allowed to reach 150°C and held there for an appreciable length of time the fingers may lose their temper, or springy characteristics. If this were to happen poor contact and resultant arcing can take place which can burn/melt the metal at the tube surface, which is a part of the vacuum envelope. Catastrophic tube loss could occur.

Air flow must be applied before or simultaneously with the application of power, including the tube filament and should normally be maintained for a short period of time after all power is removed to allow for tube cool down.

Pressure drop will be higher if the SK-360 socket is used unless additional air passages are provided around the mounted socket.

## Inlet air temperature= 25°C

	Anode dissipation (kW)	Air flow (CFM)	Pressure drop (in. of water)
Sea level	12.5	257	0.6
	15.0	367	1.0
	17.5	498	1.5
	20.0	652	2.4
5000 feet	12.5	311	0.6
	15.0	444	1.1
	17.5	603	1.7
	20.0	789	2.7
10,000 feet	12.5	377	0.7
	15.0	537	1.2
	17.5	730	1.9
	20.0	955	3.0

## Inlet air temperature= 35°C

	Anode dissipation (kW)	Air flow (CFM)	Pressure drop (in. of water)
Sea level	12.5	299	0.7
	15.0	426	1.2
	17.5	579	1.9
	20.0	758	2.9
5000 feet	12.5	362	0.7
	15.0	516	1.3
	17.5	701	2.1
	20.0	917	3.3
10,000 feet	12.5	438	0.8
	15.0	625	1.4
	17.5	848	2.4
	20.0	1111	3.8

## Inlet air temperature= 50°C

	Anode dissipation (kW)	Air flow (CFM)	Pressure drop (in. of water)
Sea level	12.5	379	0.9
	15.0	540	1.6
	17.5	733	2.6
	20.0	960	4.1
5000 feet	12.5	459	1.0
	15.0	654	1.8
	17.5	888	3.0
	20.0	1162	4.7
10,000 feet	12.5	555	1.1
	15.0	791	2.0
	17.5	1075	3.4
	20.0	1407	5.4

## ELECTRICAL

**ABSOLUTE MAXIMUM RATINGS** - Values shown for each type of service are based on the "absolute system" and are not to be exceeded under any service conditions. Ratings are limiting values outside which the serviceability of the tube may be impaired.

In order not to exceed absolute ratings the equipment de-signer has the responsibility of determining an average de-sign value for each rating below the absolute value of that rating by a safety factor so that the absolute values will never be exceeded under any usual conditions of supply-voltage variation, load variation, or manufacturing variation in the equipment itself. It does not necessarily follow that combinations of absolute maximum ratings can be attained simultaneously.

**FILAMENT WARMUP** - In-rush current should be limited to 300 amperes. A suitable step-start procedure can accomplish this, or an impedance-limited transformer de-signed for this purpose can be used. Once normal filament voltage has been applied, a warm-up period of five seconds is generally sufficient before commencing operation at full power.

**FILAMENT OPERATION** - This tube is designed for commercial service, with no more than one normal off/on filament cycle per day. If additional cycling is anticipated it is recommended the user contact an Applications Engineer at CPI Eimac for additional information.

With a new tube, or one that has been in storage for some period of time, operation with filament voltage only applied for a period of 30 to 60 minutes is recommended before full operation begins. This allows the active getter mounted within the filament structure to absorb any residual gas molecules, which have accumulated during storage.

At rated (nominal) filament voltage the peak emission capability of the tube is many times that needed for communications service. A reduction in filament voltage will lower the filament temperature, which will substantially increase life expectancy. The correct value of filament voltage should be determined for the particular application. It is recommended the tube be operated at full nominal voltage for an initial stabilization period of 100 to 200 hours before any action is taken to operate at reduced voltage. The voltage should gradually be reduced until there is a slight degradation in performance (such as power output or distortion.)

The voltage should then be increased a few tenths of a volt above the value where performance degradation was noted for operation. The operating point should be rechecked after 24 hours.

Filament voltage should be closely regulated when voltage is to be reduced below nominal in this manner, to avoid any possible adverse influence by normal line voltage variations.

Periodically throughout the life of the tube the procedure outlined above for voltage reduction should be repeated with voltage reset as required, to assure best tube life. Filament voltage should be measured at the tube base or socket with a known-accurate rms-responding meter.

EIMAC Application Bulletin #18 titled "Extending Transmitter Tube Life" contains valuable information and is available on request.

**ELECTRODE DISSIPATION RATINGS** - The maximum dissipation ratings for the 4CX20,000C must be respected to avoid damage to the tube. An exception is the anode dissipation which may be permitted to rise above the rated maximum during brief periods (ten seconds maximum) such as may occur during tuning.

**GRID OPERATION** - The maximum rated control grid dissipation is 200 Watts, determined approximately by the product of the dc grid current and the peak positive grid voltage. A protective spark-gap device should be connected between the control grid and the cathode to guard against excessive voltage. The maximum dc grid voltage (bias) is -1.5 kvdc.

**SCREEN OPERATION** - The maximum screen grid dissipation is 450 Watts. With no ac applied to the screen grid, dissipation is simply the product of dc screen voltage and the dc screen current. With modulation dissipation is dependent on rms screen voltage and rms screen current.

CW operation at VHF frequencies above the maximum frequency rating for CW service may add significantly to the total screen grid dissipation due to the ac charging current in internal capacitance between the screen grid and anode. Operation at lower anode voltage and/or lower drive levels will reduce the dissipation.

Anode voltage, anode loading, or bias voltage must never be removed while filament and screen voltages are present, since screen dissipation ratings will be exceeded. A protective spark-gap device should be connected between the screen grid and the cathode to guard against excessive voltage.

The tube may exhibit reversed (negative) screen current under some operating conditions. The screen supply voltage must be maintained constant for any values of negative and positive screen current which may be encountered. Dangerously high anode current may flow if the screen power supply exhibits a rising voltage characteristic with negative screen current. Stabilization may be accomplished with a bleeder resistor connected from screen to cathode to assure that net screen supply current is always positive. This is essential if a series electronic regulator is employed.

**FAULT PROTECTION** - In addition to the normal anode over-current interlock, screen current interlock, and cooling air flow interlock, the tube must be protected from internal damage caused by an internal anode arc which may occur at high voltages. A protective resistance of approx. 5 to 10 Ohms, 500 Watts should always be connected in series with the tube anode to absorb power supply stored energy if an internal arc should occur. If power supply stored energy is high an electronic crowbar, which will discharge power supply capacitors in a few microseconds after the start of an arc, is recommended. The protection criteria for each electrode supply is to short each electrode to ground, one at a time, through a vacuum relay switch and a 6-inch section of #30 AWG copper wire. The wire will remain in-tact if protection is adequate. EIMAC's Application Bulletin #17 titled "Fault Protection" contains considerable detail and is available on request.

**HIGH VOLTAGE** - Normal operating voltages used with this tube are deadly. The equipment must be designed properly and operating precautions must be followed. Design all equipment so that no one can come in contact with high voltages. All equipment must include safety enclosures for

high voltage circuits and terminals, with interlock switches to open primary circuits of the power supply and to discharge high voltage capacitors whenever access doors are opened. Interlock switches must not be bypassed or "cheated" to allow operation with access doors open. Always remember that HIGH VOLTAGE CAN KILL.

**RADIO-FREQUENCY RADIATION** - Avoid exposure to strong rf fields even at relatively low frequency. Absorption of rf energy by human tissue is dependent on frequency. Under 300 MHz most of the energy will pass completely through the human body with little attenuation or heating effect. Public health agencies are concerned with the hazard, and the published OSHA (Occupational Safety and Health Administration) or other local recommendations to limit prolonged exposure of rf radiation should be followed.

**INTERELECTRODE CAPACITANCE** - The actual internal electrode capacitance of a tube is influenced by many variables in most applications, such as stray capacitance to the chassis, capacitance added by the socket used, stray capacitance between tube terminals and wiring effects. To control the actual capacitance values within the tubes, as the key component involved, the industry and Military Services use a standard test procedure as described in Electronic Industries Association Standard

RS-191. This requires the use of specially constructed test fixtures which effectively shield all external tube leads from each other and eliminates any capacitance reading to "ground." The test is performed on a cold tube. Other factors being equal, controlling internal tube capacitance in this way normally assures good interchangeability of tubes over a period of time, even when the tube may be made by different manufacturers.

The capacitance values shown in the manufacturer's technical data, or test specifications, normally are taken in accordance with Standard RS-191.

The equipment designer is therefore cautioned to make allowance for the actual capacitance values which will exist in any normal application. Measurements should be taken with the socket and mounting which represent approximate final layout if capacitance values are highly significant in the design.

**SPECIAL APPLICATIONS** - When it is desired to operate this tube under conditions widely different from those listed here, write to CPI MPP, Eimac Operation, Applications Engineering, 607 Hansen Way, Palo Alto, CA 94304 U.S.A.

## OPERATING HAZARDS

Proper use and safe operating practices with respect to power tubes are the responsibility of equipment manufacturers and users of such tubes. All persons who work with and are exposed to power tubes, or equipment that utilizes such tubes, must take precautions to protect themselves against possible serious bodily injury. **DO NOT BE CARELESS AROUND SUCH PRODUCTS.**

The operation of this tube may involve the following hazards, any one of which, in the absence of safe operating practices and precautions, could result in serious harm to personnel.

**HIGH VOLTAGE** - Normal operating voltages can be deadly. Remember that **HIGH VOLTAGE CAN KILL.**

**LOW-VOLTAGE HIGH-CURRENT CIRCUITS** - Personal jewelry, such as rings, should not be worn when working with filament contacts or connectors as a short circuit can produce very high current and melting, resulting in severe burns.

**RF RADIATION** - Exposure to strong RF fields should be avoided, even at relatively low frequencies. **CARDIAC PACEMAKERS MAY BE AFFECTED.**

**HOT SURFACES** - Surfaces of tubes can reach temperatures of several hundred°C and cause serious burns if touched for several minutes after all power is removed.

**MATERIAL COMPLIANCE** - This product and package conforms to the conditions and limitations specified in 49CFR 173.424 for radioactive material, excepted package-instruments or articles, UN2910. In addition, this product and package contains no beryllium oxide (BeO).

Communications & Power Industries Tetrode

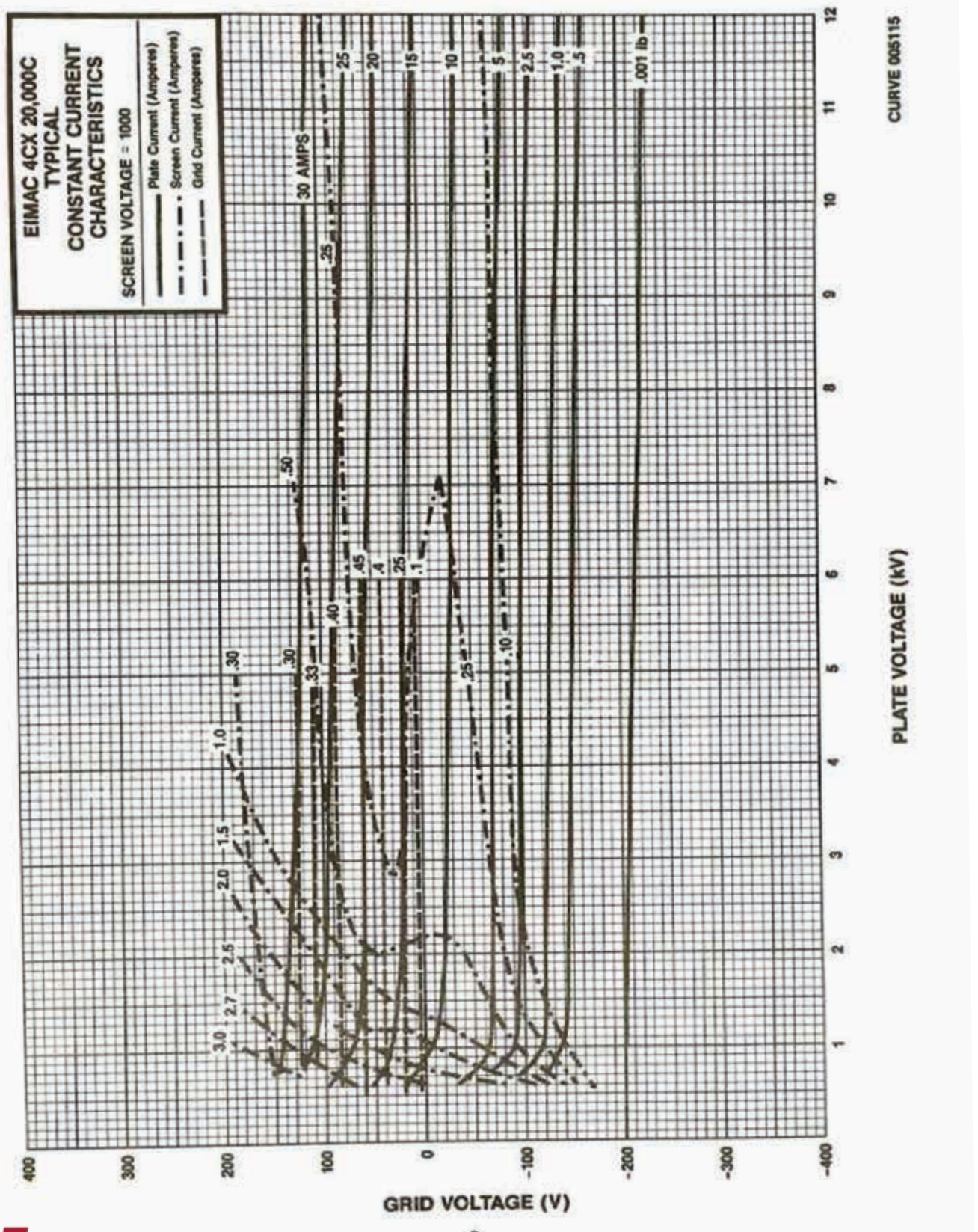

# CPI 20 kW VHF Radial Beam Power Tetrode: 4CX20000C

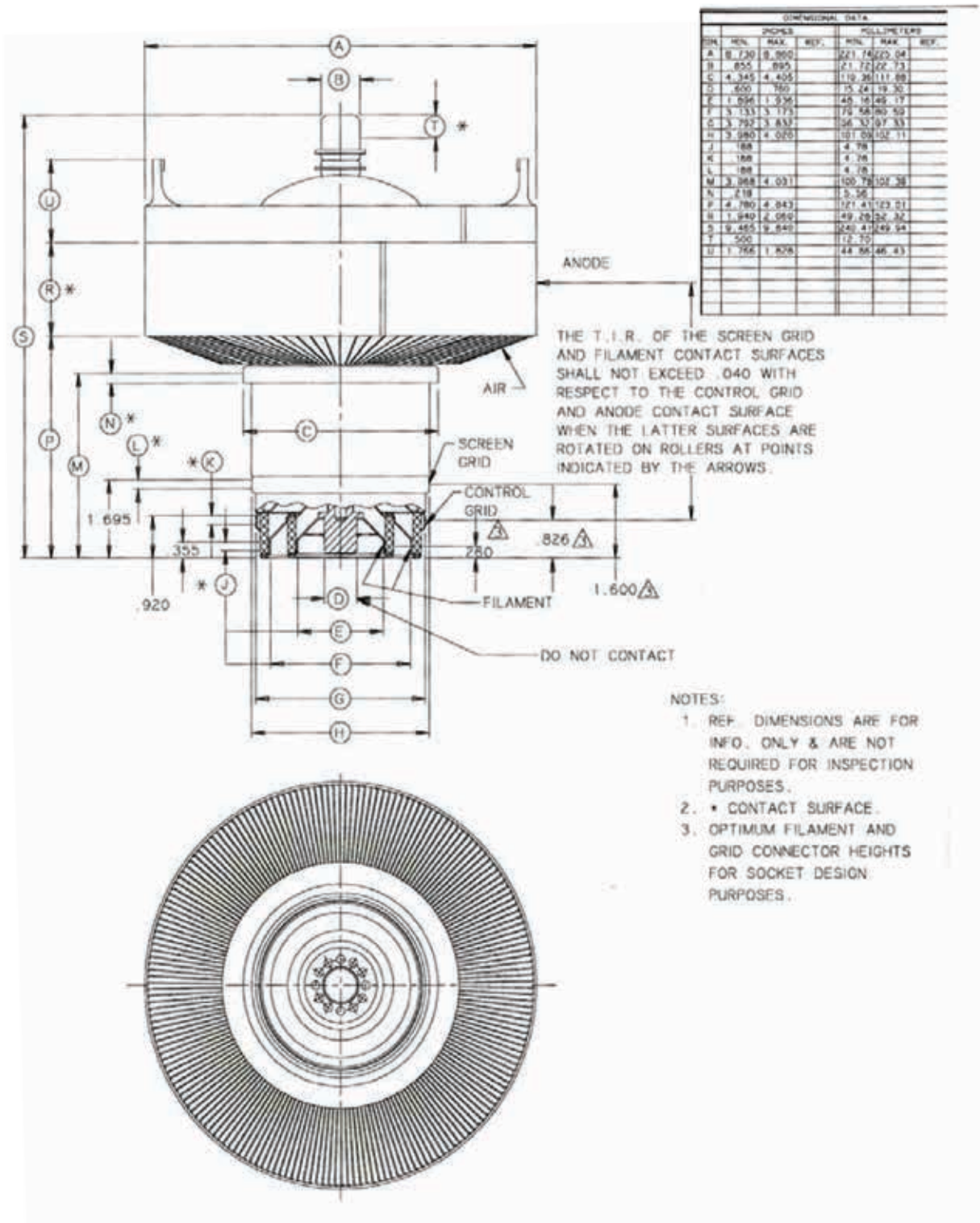

With a history of producing high quality products, we can help you with your tetrode.

Contact us at [MPPMarketing@cpil.com](mailto:MPPMarketing@cpil.com) or call us at +1 650-846-2800. The data should be used for basic information only

Formal, controlled specifications may be obtained from CPI for use in equipment design.



**Microwave Power Products Division**  
811 Hansen Way  
Palo Alto, California  
USA 94304

tel +1 650-846-2800  
fax +1 650-856-0705  
email [MPPMarketing@cpil.com](mailto:MPPMarketing@cpil.com)  
web [www.cpii.com/MPP](http://www.cpii.com/MPP)

For more detailed information, please refer to the corresponding CPI technical description if one has been published, or contact CPI. Specifications may change without notice as a result of additional data or product refinement. Please contact CPI before using this information for system design.

©2020 Communications & Power Industries LLC. Company proprietary; use and reproduction is strictly prohibited without written authorization from CPI.